

# AC Analysis of Resonant Converters Using PSpice – A Quicker Approach

M. Borage<sup>1</sup>S. Tiwari<sup>1</sup>

**Abstract**–A method of AC analysis of resonant converters using general purpose simulation software, PSpice, is proposed in this paper. A method of describing a resonant network using global variables, without having to specify actual component values, is proposed. The normalized results are directly obtained from the simulation, which can then be used for comparative evaluation. Thus the method eliminates the derivation, calculations and plotting of large number of mathematical expressions. The application of proposed method is exemplified with LCL-T resonant converter. The correctness and applicability is demonstrated by comparing the results obtained using proposed method with those obtained from mathematical expressions reported earlier. The proposed method is shown to be very useful for quicker visualization of converter characteristics, calculation of component ratings in normalized form, evaluation of converter performance and optimized converter design.

**Keywords**–Resonant converter, simulation, ac analysis

## I. INTRODUCTION

Resonant converters (RCs) offer low switching losses due to Zero Voltage Switching (ZVS) and/or Zero Current Switching (ZCS) making them popular for high frequency and particularly, high power applications. The applications mostly include, but not limited to, DC power supplies for industrial, commercial and domestic applications, high frequency AC power supplies for induction heating, power factor correction and discharge lamp ballast. The series [1] and parallel [2] resonant converters (SRC and PRC, respectively) are basic RC topologies with two reactive elements. Due to their simplicity, these circuits are widely used. However, they have some limitations that may preclude their application in some cases. To remove these limitations, three element RCs were investigated [3]. And, in a step further, RCs with four energy storage elements were presented [4]. Although additional reactive elements increase component count, size, weight and cost, these higher-order RCs have been reported to exhibit interesting and useful characteristics. As wide variety of topologies is available with promising characteristics and some limitations, analysis and comparative evaluation becomes necessary for proper choice of topology for a particular application.

The design and analysis of RCs has been performed using different methods such as state-space approach [5], state-plane diagrams [6] and AC analysis [7]. The AC analysis of RCs is the simplest and fairly accurate method of analysis. In this method, it is assumed that only the fundamental component of the square-wave voltage input

to the resonant network contributes to the power transfer to output. The transformer, rectifier and filter are replaced by equivalent AC resistance. Since the AC analysis is simple, faster and fairly accurate method, it is very useful for comparative analysis [8]. Still, if a comparative evaluation is to be performed among a group of large number of circuits, deriving, plotting and examining the characteristics becomes cumbersome and time consuming. For quicker visualization of characteristics the capabilities of modern circuit simulation packages, such as PSpice [9], [10] can be used. The PSpice and most of the other simulation software are numerical simulation program for electronic circuits and therefore actual component values are required to be specified. Thus the simulator gives particular solution of the defined circuit. The results of the particular solution need to be normalized to suitable base values to extract the generalized results for comparison.

In this paper, a method of generalized AC analysis of RCs using PSpice is described. The proposed method is easy to use and is fast. In the proposed method, any resonant network is defined using global variables without having to specify actual component values. Normalized results are directly obtained from the simulation, which are directly usable for comparative evaluation. Thus the method eliminates the derivation with subsequent calculations and plotting of large number of expressions for each circuit. On the other hand, the proposed method can also be used to verify the correctness of derived transfer functions. The outline of paper is as follows. The AC analysis of RCs is briefly reviewed first. The circuit description of LCL-T RC [11]-[17] is briefed in since it is used to exemplify the principal idea of proposed method. Subsequently, the proposed circuit description of a resonant network for obtaining normalized results directly from the simulation is explained. The results and validity of proposed method in analysis and design optimization of RC are discussed. Since experimental results have already been shown to be in conformity of the analytical predictions [11], the validity of proposed simpler method is demonstrated by comparing the results of proposed method with those obtained from detailed analytical derivations and calculations, without separately comparing them with experimental results once again.

## II. AC ANALYSIS OF RESONANT CONVERTERS

Block diagram of a dc-dc voltage-source RC is shown in Fig. 1(a). The input to the resonant network is a high-frequency square-wave voltage implemented using bridge inverter. The resonant network is composed of inductors and capacitors. The output of resonant network is rectified and filtered to get desired dc output. The filter can be an inductive filter (e.g. LC-filter) or a capacitive filter. The equivalent circuit for AC analysis is shown in Fig. 1(b).

The paper first received 4 Nov 2010 and in revised form 17 Dec 2012.

Digital Ref: APEJ-2012-12-308

<sup>1</sup> Power Supplies and Industrial Accelerator Division, Raja Ramanna Centre for Advanced Technology, Indore 452013, India.

E-mail: mbb@rrcat.gov.in, sunil@rrcat.gov.in

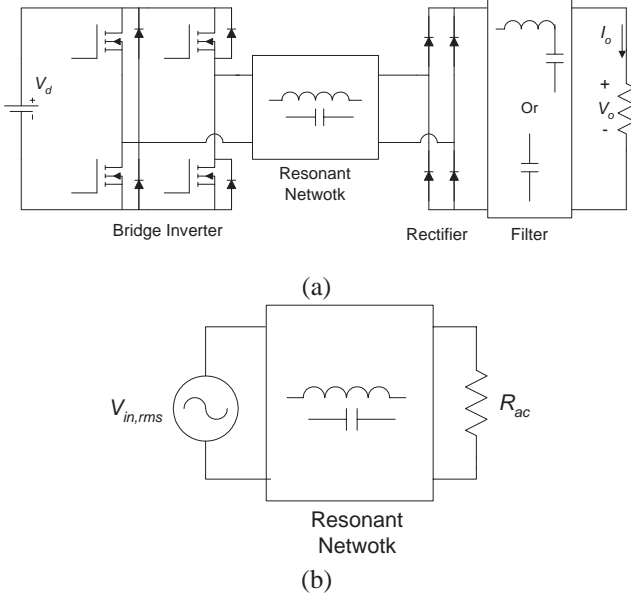

Fig. 1: (a) Block diagram of a voltage-source resonant converter.  
(b) AC equivalent circuit of a resonant converter.

The square-wave input voltage to resonant network is replaced by its fundamental component. The RMS fundamental component of input square-wave voltage is,

$$V_{in,rms} = \frac{2\sqrt{2}}{\pi} V_d \quad (1)$$

$V_d$  being the input dc voltage. The rectifier and filter are replaced by equivalent AC resistance,  $R_{ac}$ . For rectifier with inductive filter:

$$R_{ac} = \frac{\pi^2}{8} R_L \quad (2a)$$

And, for rectifier with capacitive filter:

$$R_{ac} = \frac{8}{\pi^2} R_L \quad (2b)$$

where  $R_L$  is the load resistance. For the network of Fig. 1(b), the expressions for various currents and voltages in the circuits are derived. For obtaining normalized results, typically following definitions and base values are used: Base frequency = resonant frequency ( $f_o$ ); Base voltage =  $V_d$ ; Base current =  $(V_d/Z_n)$ , where  $Z_n$  is the characteristic impedance of resonant network and is defined as:

$$Z_n = \sqrt{\frac{L}{C}} \quad (3)$$

$L$  and  $C$  being respectively the values of inductor and capacitor in the resonant network. The voltage and current gains of the resonant network are respectively defined as,

$$M = \frac{V_o}{V_d} \quad \text{and} \quad H = \frac{I_o}{(V_d/Z_n)} \quad (4)$$

where,  $V_o$  and  $I_o$  are output dc voltage and current, respectively.

### III. LCL-T RESONANT CONVERTER

The analysis, optimization and design of LCL-T RC using AC analysis is reported in [11]. In this section the circuit description of LCL-T RC is briefed and salient equations

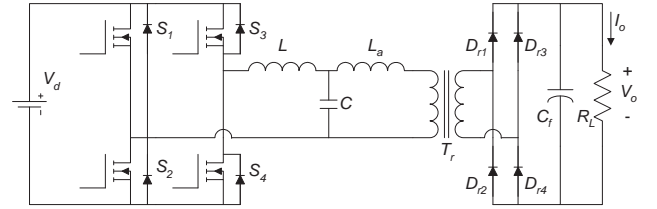

Fig. 2: Circuit diagram of full-bridge LCL-T resonant converter.

are reproduced for ready reference and completeness since the converter is used to exemplify the principal idea of proposed method. The circuit diagram of full-bridge LCL-T RC is shown in Fig. 2. The LCL-T resonant network is composed of inductors  $L$ ,  $L_a$  and capacitor  $C$ . The full-bridge converter (using MOSFET switches  $S_1 - S_4$ ) drives the input port of the resonant network with high-frequency symmetrical square-wave voltage waveform of amplitude  $\pm V_d$ . At the output port of the resonant network an isolation transformer,  $T_r$ , matches the required output voltage,  $V_o$ , and current,  $I_o$ , to the available dc input,  $V_d$ . A diode bridge rectifier ( $D_{r1}$  through  $D_{r4}$ ) and filter capacitor ( $C_f$ ) convert high-frequency ac to output dc. In the following analysis, the transformer turns ratio is assumed to be unity, without losing generality. The resonant frequency and  $Q$  of the resonant network are defined as,

$$f_o = \frac{1}{2\pi\sqrt{LC}} \quad \text{and} \quad Q = \frac{2\pi f_o L}{R_L} = \frac{Z_n}{R_L} \quad (5)$$

The ratio of inductors is defined as,

$$\gamma = \frac{L_a}{L} \quad (6)$$

The voltage and current gains can be derived as,

$$M = \frac{1}{(1 - f_n^2) + j \frac{\pi^2}{8} Q [(1 + \gamma)f_n - f_n^3 \gamma]} \quad (7a)$$

$$H = \frac{1}{Q \frac{1}{(1 - f_n^2) + j \frac{\pi^2}{8} [(1 + \gamma)f_n - f_n^3 \gamma]}} \quad (7b)$$

where  $f_n$  is the normalized switching frequency. We see from (7) that the load current is independent of load if operated at  $f_n = f_i = 1$ ,  $f_i$  being the normalized switching frequency where  $H$  is independent of  $Q$ , and,

$$H|_{f_n=f_i} = \frac{8}{\pi^2} \quad (8)$$

Thus, the LCL-T RC behaves as constant current source when operated at  $f_n = f_i = 1$ , if the input voltage is constant. Additionally, if  $\gamma = 1$  the output voltage and current of the full-bridge converter are in phase resulting in ZCS operation and the lowest conduction loss in the switches. The converter optimized for minimum ( $kVA/kW$ ) rating of the resonant network at  $\gamma = f_n = 1$  gives:

$$Q_{opt}|_{f_n=f_i} = \frac{8}{\pi^2} \quad (9)$$

Generalized expressions for normalized voltage and current ratings of all the reactive components in the resonant network are derived and reported in [11].

## IV. PROPOSED AC ANALYSIS USING PSpICE

The PSpice software is numerical simulation program for electronic circuits and therefore actual component values are required to be specified. Thus the simulator gives particular solution of the defined circuit. The results of the particular solution need to be normalized to suitable base values to extract the generalized results for comparison. In the circuit description proposed in the following paragraphs, the resonant network can be described in terms of global variables or parameters. We need not to specify actual component values. Normalized results are directly obtained from the simulation.

The frequency response or AC circuit analysis of PSpice calculates all the ac node voltages and currents over a swept range of frequency. Therefore, the primary variable is chosen as  $f_n$ . To make  $f_n$  independent of  $f_o$ , the latter is selected to be unity. Taking  $L=C=0.159154943$  we get from (5),  $f_o = 1$ , and, from (3),  $Z_n=1$ . With this choice and from (5) we simplify the definition of value of  $R_{ac}$  in terms of another global variable  $Q$  as,

$$R_{ac} = \frac{8}{\pi^2} \frac{1}{Q} \quad (10)$$

Recall that LCL-T RC has capacitive output filter. For converters with inductive output filter, the value of  $R_{ac}$  in terms of  $Q$  is given by,

$$R_{ac} = \frac{\pi^2}{8} \frac{1}{Q} \quad (11)$$

Having defined  $\gamma$  as another independent variable, from (6),

$$L_a = 0.159154943 \cdot \gamma \quad (12)$$

Taking  $V_d=1$ , both the base voltage and current become unity since  $Z_n=1$ . Therefore, if we define the amplitude of ac voltage source in PSpice as,

$$V_{in,rms} = \frac{2\sqrt{2}}{\pi} \quad (13)$$

then, the amplitude of various voltages and currents calculated by PSpice will directly be equal to normalized rms value.

The circuit netlist for LCL-T RC for AC analysis in PSpice is given in appendix A. The analysis sweeps the frequency and parameter  $Q$  is also varied in the specified range.

## V. RESULTS AND DISCUSSIONS

The circuit netlist of appendix A was simulated on PSpice for the ac analysis of LCL-T RC. The simulation was completed in few seconds. In the graphical waveform analyzer for PSpice, Probe, the results are directly plotted in normalized form. The expression derived and reported in [11] are used for numerically calculate and plot various characteristics for direct comparison and validation of the results obtained with proposed method. The results obtained from simulation are shown in part (a) of Fig. 3 to Fig. 8. The y-axis label of these figures is same as that shown in part (b) of respective figures. Also, the x-axis

label "frequency" mentioned in the simulation results of part (a) of Fig. 3 to Fig. 7 actually correspond to the normalized switching frequency,  $f_n$ , since both are same in the proposed method as discussed in the previous section.

## A. Converter Gain

The voltage and current gains of the RC are defined by (4) and summarized by (7). The plots of  $M$  as a function of  $f_n$  for  $\gamma=1$  and for different values of  $Q$  are shown in Fig.3. The results obtained using proposed method are shown in Fig. 3(a) and those obtained using mathematical analysis are shown in Fig. 3(b). Similarly, simulated and calculated plots of  $H$  as a function of  $f_n$  for  $\gamma=1$  and for different values of  $Q$  are shown in Fig.4(a) and Fig. 4(b), respectively. The trace expressions to plot  $M$  and  $H$  are summarized in table 1. The plots obtained directly using proposed method are seen to match exactly with those obtained from mathematical expressions. It is interesting to note that LCL-T RC offers load independent output current when operated at  $f_n=1$ .

## B. Component Ratings

The proposed method is very useful to quickly determine the normalized rms current and voltage ratings of different reactive components in the resonant network without

**Table 1: The trace expressions in Probe to plot  $M$  and  $H$**

Parameter	Trace expression in Probe
$M$	V(3)/V(1)
$H$	I(Rac)*0.9003 <sup>#</sup>

<sup>#</sup>  $I_o$  is equal to the average value of full wave rectified  $I_{Rac}$ .

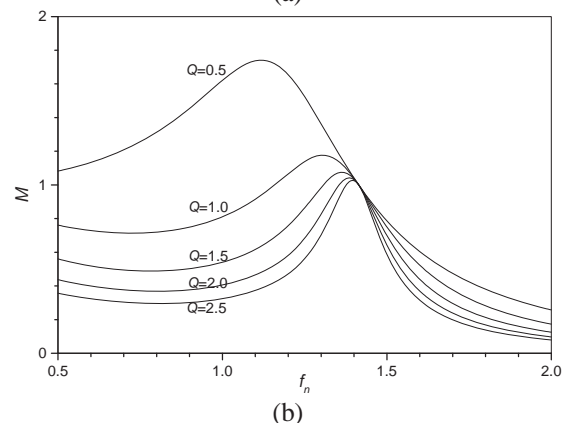
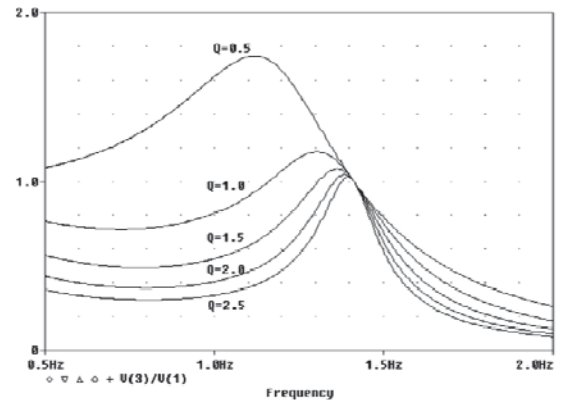

Fig. 3: The plots of  $M$  as a function of  $f_n$  for  $\gamma=1$  obtained using (a) proposed method (b) mathematical expression.

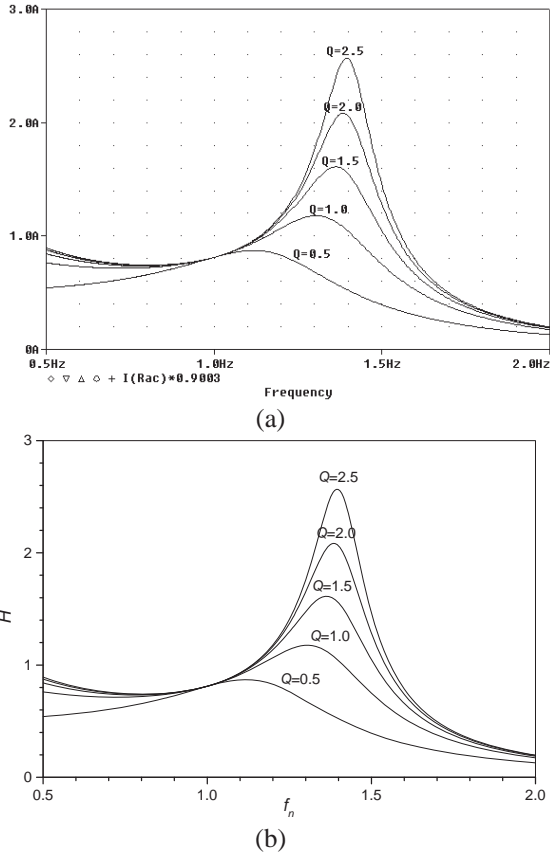

Fig. 4: The plots of  $H$  as a function of  $f_n$  for  $\gamma=1$  obtained using (a) proposed method (b) mathematical expression.

having to individually derive the expressions. The trace expressions to plot normalized rms voltage and current rating of inductors and capacitor in LCL-T RC are summarized in table 2. Illustratively, Fig. 5 and Fig. 6 show the normalized rms current in inductor  $L$  and capacitor  $C$ , respectively, as a function of  $f_n$  for  $\gamma=1$  and for different values of  $Q$  obtained using proposed method and from mathematical expressions reported in [11]. Once again, the plots obtained directly using proposed method are seen to match exactly with those obtained from mathematical expressions confirming the validity of proposed method.

### C. Converter Performance

Apart from its usefulness to quickly determine the component ratings and visualize converter characteristics, the proposed method and capabilities of PSpice can be used to evaluate the performance of the converter and

**Table 2: Trace expressions in Probe to plot normalized rms voltage and current rating of inductors and capacitor**

Parameter	Trace exp. in Probe
Normalized rms current in inductor $L$	I(L)
Normalized rms current in inductor $L_a$	I(La)
Normalized rms current in capacitor $C$	I(C)
Normalized rms voltage across inductor $L$	V(1,2)
Normalized rms voltage across inductor $L_a$	V(2,3)
Normalized rms voltage across capacitor $C$	V(2)

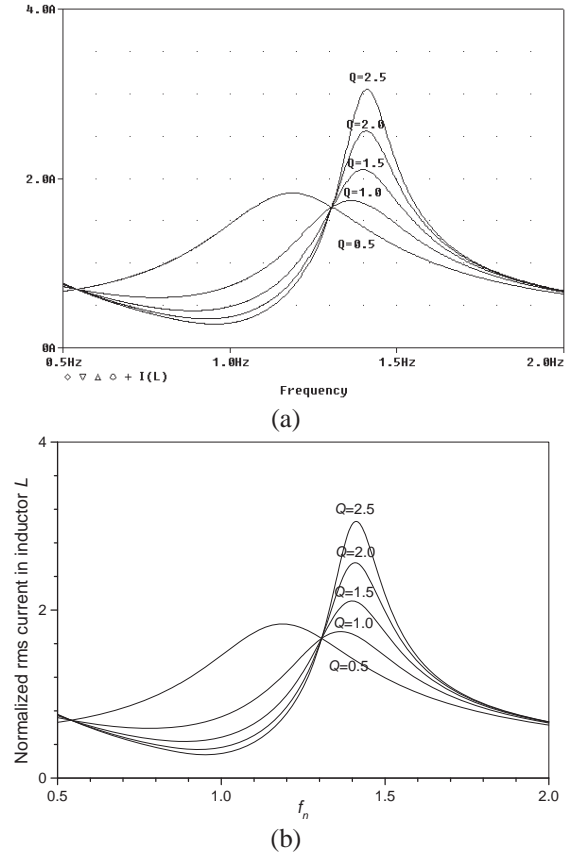

Fig. 5: The plots of normalized rms current in inductor  $L$  as a function of  $f_n$  for  $\gamma=1$  obtained using (a) proposed method (b) mathematical expression.

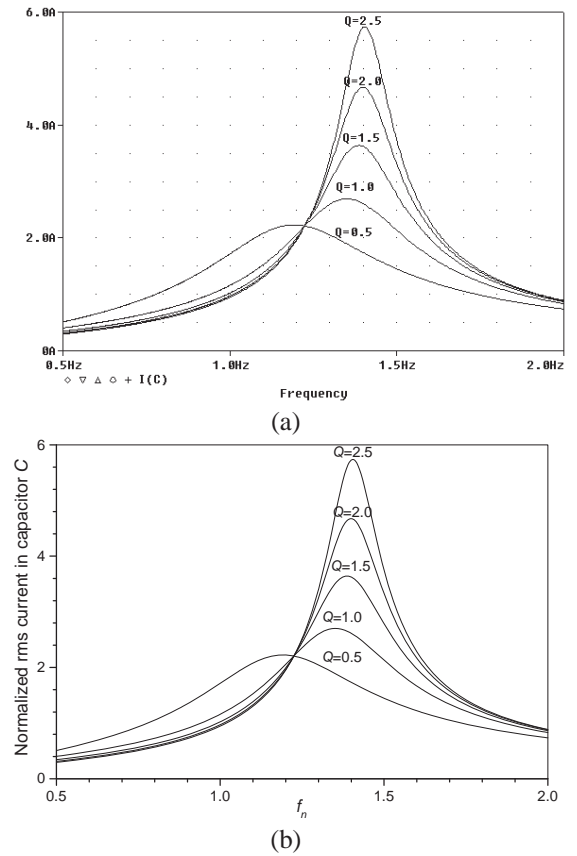

Fig. 6: The plots of normalized rms current in capacitor  $C$  as a function of  $f_n$  for  $\gamma=1$  obtained using (a) proposed method (b) mathematical expression.

derive the condition for its optimized design. LCL-T RC is seen to behave as constant current source when operated at  $f_n=1$ . This property is very useful for its application in applications such as electromagnets, capacitor charging, battery charging, arc welding, semiconductor laser diode drivers etc. The effect of choice of  $Q$  by design on ratings of different parameters needs to be examined for operation at  $f_n=1$ . The trace expressions to plot normalized rms voltage and current rating of inductors and capacitor at  $f_n=1$  in LCL-T RC are summarized in table 3. Illustratively, Fig. 7 compares the normalized rms current in inductor  $L$  and capacitor  $C$  as a function of  $Q$  for  $\gamma=1$  and at  $f_n=1$  obtained using proposed method and from mathematical expressions reported in [11]. The applicability of proposed method in evaluating converter performance is thus proved.

The reactive components in an RC increase its size. Therefore, the RCs are optimized for minimum size of resonant network. The ( $kVA/kW$ ) rating of resonant network is considered as an index for the physical size of the resonant network. The trace expressions to plot ( $kVA/kW$ ) rating of LCL-T RC in Probe can be written as:

$$\frac{(YatX(I(L),1)*YatX(V(1,2),1)+YatX(I(La),1)*YatX(V(2,3),1)+YatX(I(C),1)*YatX(V(2),1))}{(YatX(v(3),1)*YatX(I(Rac),1))}$$

Fig. 8 compares the ( $kVA/kW$ ) rating of LCL-T RC as a function of  $Q$  for  $\gamma=1$  and at  $f_n=1$  obtained using proposed method and from mathematical expressions reported in [11]. The optimum value of  $Q$ , where ( $kVA/kW$ ) is minimum, is observed to be  $Q=0.81$ , consistent with (9).

## VI. CONCLUSION

A large number of two-, three- and four-element RCs topologies are reported in the literature. In order to choose a topology for particular operation, one must visualize its characteristics and compare its performance with other candidate topologies. The process involving analytical derivation of mathematical expressions describing performance characteristics and component ratings of all the candidate topologies and subsequently plotting and comparing the characteristics can be tedious, cumbersome and time consuming. For quicker evaluation of the

**Table 3: Trace expressions to plot normalized rms voltage and current rating of inductors and capacitor at  $f_n=1$**

Parameter at $f_n=1$	Trace expression in Probe
Normalized rms current in inductor $L$	YatX(I(L),1)
Normalized rms current in inductor $L_a$	YatX(I(La),1)
Normalized rms current in capacitor $C$	YatX(I(C),1)
Normalized rms voltage across inductor $L$	YatX(V(1,2),1)
Normalized rms voltage across inductor $L_a$	YatX(V(2,3),1)
Normalized rms voltage across capacitor $C$	YatX(V(2),1)

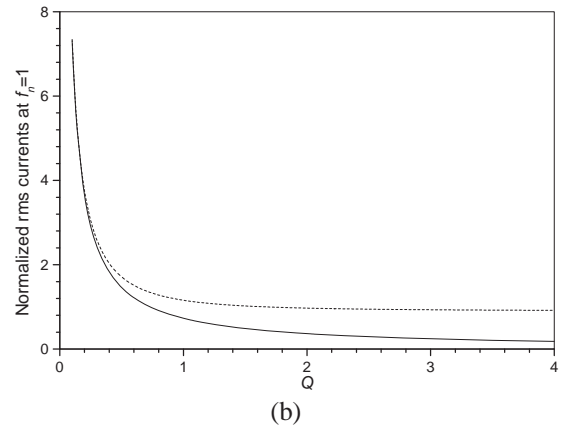
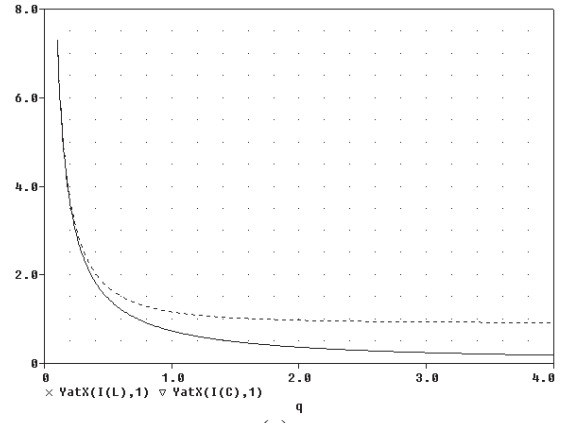

Fig. 7: The plots of normalized rms current in inductor  $L$  (continuous curve) and capacitor  $C$  (dotted curve) as a function of  $Q$  for  $\gamma=1$  and at  $f_n=1$  obtained using (a) proposed method, and (b) mathematical expression.

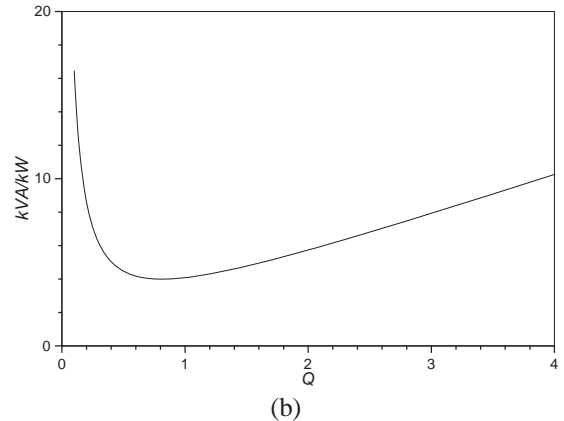
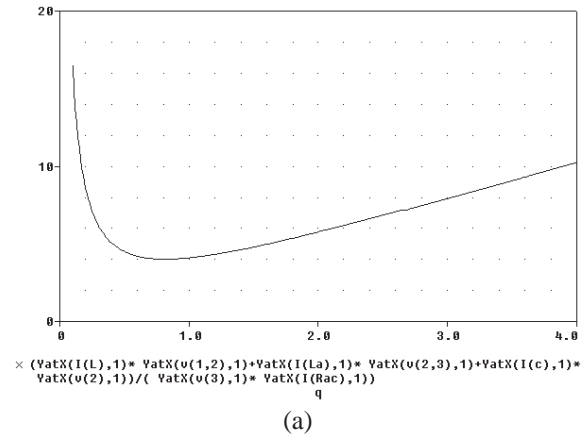

Fig.8: The variation in  $kVA/kW$  rating of LCL-T RC as a function of  $Q$  for  $\gamma=1$  and at  $f_n=1$  using (a) proposed method (b) mathematical expression.

characteristics of a particular circuit, simulation packages can be used but the results of simulation cannot directly be used for comparison with other circuits since numerical simulation software do not give results in generalized form. A quicker method of AC analysis of RCs using general purpose simulation software, PSpice, is proposed in this paper. In the proposed method, any resonant network is defined using global variables and we need not specify actual component values. Normalized results are directly obtained from the simulation, which can then directly be used for comparative evaluation. Thus the method eliminates the derivation, calculations and plotting of large number of expressions for each circuit. Additionally, the proposed method can also be used to verify the correctness of derived transfer functions. The proposed method is illustrated for LCL-T RC. The correctness and applicability is demonstrated by comparing the results obtained using proposed method with those obtained from mathematical expressions. The proposed method is shown to be very useful for quicker visualization of converter characteristics, calculation of component ratings in normalized form, evaluation of converter performance and optimized converter design.

#### APPENDIX A

\* Circuit netlist of LCL-T RC for proposed AC analysis using PSpice

```
*****Global Parameters*****
.param pi=3.14159265
.param gamma=1 ; Ratio of inductors La to L
.param q=1 ; Circuit Q value
*****Circuit Netlist*****
Vin 1 0 ac {2*sqrt(2)/pi}
L 1 2 0.1591549
La 2 3 {gamma*0.1591549}
C 2 0 0.1591549
Rac 3 0 {8/(pi*pi)*1/q}
*****Analysis Setup*****
.ac dec 1000 0.5 2
.step param q 0.1 4 0.01
.probe
.end
```

#### REFERENCES

- [1] V. Vorperian, S. Cuk, "A complete dc analysis of series resonant converter", in Proc. IEEE PESC'82, pp. 85-100, 1982.
- [2] A. K. S. Bhat and M. M. Swamy, "Analysis and design of high frequency parallel resonant converter operating above resonance," in Proc. IEEE APEC'88, pp.182-189, 1988.
- [3] R. P. Severns, "Topologies for three-element resonant converters", *IEEE Trans. on Ind. Electron.*, vol. 7, no. 1, pp. 89-98, 1992.
- [4] I. Bataresh, "Resonant converter topologies with three and four energy storage elements", *IEEE Trans. on Ind. Electron.*, vol. 9, no. 1, pp. 64-73, 1994.
- [5] A. Bhat and S. Dewan, "Analysis and design of high frequency resonant converter with LCC type commutation," *IEEE Trans. on Ind. Electron.*, vol. PE-2, no. 4, pp. 291-301, 1987.
- [6] I. Batarseh and K. Siri, "Generalized approach to the small-signal modeling of dc-dc resonant converters," *IEEE Trans.*

*on Aerospace and Electronic Syst.*, vol. 29, no. 3, pp. 894-909, 1993.

- [7] R. Steigerwald, "Comparison of Half-Bridge Resonant Converter Topologies," *IEEE Trans. on Ind. Electron.*, vol. 3, no. 2, pp. 174-182, 1988.
- [8] M. Borage, S. Tiwari and S. Kotaiah, "Comparison of three-element V-N-V resonant converters", in Proc. India International Conference on Power Electronics (IICPE), Mumbai, India, 2002.
- [9] 'Orcad PSpice A/D – User's guide', Orcad Inc., 9300 SW Nimbus Avenu, Beavertron, OR 97008 USA. 1998.
- [10] M. Rashid, 'SPICE for circuits and electronics simulation using PSpice', Prentice-Hall of India Private Limited, 2nd edition, 1996.
- [11] M. Borage, S. Tiwari and S. Kotaiah, "Analysis and Design of LCL-T Resonant Converter as a Constant-current Power Supply", *IEEE Trans. on Ind. Electron.*, vol. 52, no. 6, pp.1547-1554, December 2005.
- [12] M. Borage, S. Tiwari, S. Kotaiah, "LCL-T resonant converter with clamp diodes: A novel constant-current power supply with inherent constant-voltage limit," *IEEE Trans. Ind. Electron.*, vol. 54, no. 2, pp. 741 - 746, April 2007.
- [13] M. Borage, S. Tiwari and S. Kotaiah, "A constant-current, constant-voltage half-bridge resonant power supply for capacitor charging," *IEE Proc. Electr. Power. Appl.*, vol. 153, no. 3, pp. 343-347, May 2006.
- [14] M. Borage, K. V. Nagesh, M. S. Bhatia and S. Tiwari, "Design of LCL-T resonant converter including the effect of transformer winding capacitance," *IEEE Trans. Ind. Electron.*, vol. 56, no. 5, pp. 1420-1427, May 2009.
- [15] M. Borage, K. V. Nagesh, M. S. Bhatia and S. Tiwari, "Characteristics and design of an asymmetrical duty-cycle controlled LCL-T resonant converter," *IEEE Trans. Power Electron.*, vol. 24, no. 10, pp. 2268-2275, October 2009.
- [16] Mangesh Borage, K. V. Nagesh, M. S. Bhatia and Sunil Tiwari, "Resonant immittance converter topologies", *IEEE Trans. on Ind. Electron.*, vol. 58, no. 3, pp. 971-978, March 2011.
- [17] Mangesh Borage, K. V. Nagesh, M. S. Bhatia and Sunil Tiwari, "Approximate equivalent circuit modeling and analysis of Type-II resonant immittance converters", *Journal of Power Electronics*, vol. 12, no. 2, pp. 317-325, March 2012.

#### BIOGRAPHIES



**Mangesh Borage** received B. E. degree (1993), M. Tech. degree (1996) and Ph. D. (2011) in electrical engineering. He joined Bhabha Atomic Research Centre (BARC), Mumbai, India in 1994. Since 1995, he is with Raja Ramanna Centre for Advanced Technology, Indore, India. His research interests include soft-switching and resonant converters, high-frequency magnetic components and high-frequency power converters, in general.

Dr. Borage is recipient of University Merit Certificate from Shivaji University, Kolhapur, India for First Rank in Electrical Engineering in 1993. He is also a recipient of Dr. Homi Bhabha Award at BARC, Mumbai, India in 1995.



**Sunil Tiwari** received B.E. Degree from Maharaja Sayajirao University, Vadodra, India in electronics engineering in 1984. He was with Bharat Heavy Electricals Limited, Bangalore, India from 1984 to 1987 and with the Ministry of Defence, Agra, India from 1987 to 1989. Since 1989 he is with Raja Ramanna Centre for Advanced Technology Indore, India as Scientific Officer. His research interests include soft-switching and resonant techniques for

high power application and development of high stability power supplies for particle accelerators.